

Product Features

- Compliant with IEEE Std 802.3ba, 100G Ethernet LR4
- Compliant with QSFP28 MSA
- 4 cooled 25Gb/s channels LAN WDM DFB TOSA
- 4 channels PIN photo detector
- Single +3.3V power supply
- Class 1 laser safety certified
- Power consumption less than 3.5W
- Commercial operating temperature:-5°C to +70°C
- Up to 10km on SMF
- RoHS 6/6 Compliant

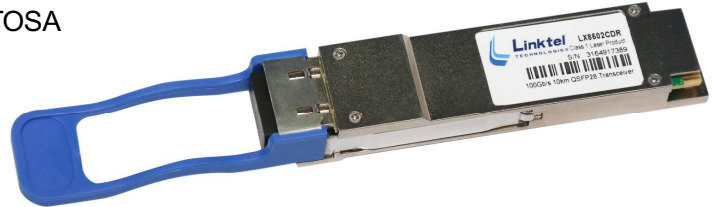

Applications

- 100GBASE-LR4 Ethernet links
- Data center

Descriptions

LX8502CDR QSFP28 transceiver modules are designed for 100 Gigabit Ethernet over single mode fiber. They are compliant with the QSFP28 MSA, IEEE 802.3ba 100GBASE-LR4. Digital diagnostics functions are available via the I2C interface, as specified by the QSFP28 MSA.

LX8502CDR are compliant with RoHS.

Ordering Information

Table 1. Ordering Information

Part Number	Transmitter	Output Power	Receiver	Sensitivity	Reach	Temp	DDM	RoHS
LX8502CDR	LWDM DFB	-4.3~ +4.5dBm	PIN	< -8.6dBm	10km	-5~ 70 °C	Available	Compliant

Pin Description

Table 2. Pin Description

Pin	Name	Function/Description	Notes
1	GND	Transmitter Ground (Common with Receiver Ground)	1
2	Tx2-	Transmitter Inverted Data Input	
3	Tx2+	Transmitter Non-Inverted Data output	
4	GND	Transmitter Ground (Common with Receiver Ground)	1
5	Tx4-	Transmitter Inverted Data Input	
6	Tx4+	Transmitter Non-Inverted Data output	
7	GND	Transmitter Ground (Common with Receiver Ground)	1
8	ModSelL	Module Select	2
9	ResetL	Module Reset	2
10	VccRx	3.3V Power Supply Receiver	
11	SCL	2-Wire serial Interface Clock	2
12	SDA	2-Wire serial Interface Data	2
13	GND	Transmitter Ground (Common with Receiver Ground)	1
14	Rx3+	Receiver Non-Inverted Data Output	
15	Rx3-	Receiver Inverted Data Output	
16	GND	Transmitter Ground (Common with Receiver Ground)	1
17	Rx1+	Receiver Non-Inverted Data Output	
18	Rx1-	Receiver Inverted Data Output	
19	GND	Transmitter Ground (Common with Receiver Ground)	1
20	GND	Transmitter Ground (Common with Receiver Ground)	1
21	Rx2-	Receiver Inverted Data Output	
22	Rx2+	Receiver Non-Inverted Data Output	
23	GND	Transmitter Ground (Common with Receiver Ground)	1
24	Rx4-	Receiver Inverted Data Output	1
25	Rx4+	Receiver Non-Inverted Data Output	
26	GND	Transmitter Ground (Common with Receiver Ground)	1
27	ModPrsl	Module Present	
28	IntL	Interrupt	2
29	VccTx	3.3V power supply transmitter	
30	Vcc1	3.3V power supply	
31	LPMode	Low Power Mode	2
32	GND	Transmitter Ground (Common with Receiver Ground)	1
33	Tx3+	Transmitter Non-Inverted Data Input	
34	Tx3-	Transmitter Inverted Data Output	
35	GND	Transmitter Ground (Common with Receiver Ground)	1
36	Tx1+	Transmitter Non-Inverted Data Input	
37	Tx1-	Transmitter Inverted Data Output	
38	GND	Transmitter Ground (Common with Receiver Ground)	1

Notes:

1. The module signal grounds are isolated from the module case.
2. This is an open collector/drain output that on the host board requires a 4.7KΩ to 10KΩ pull-up resistor to VccHost.

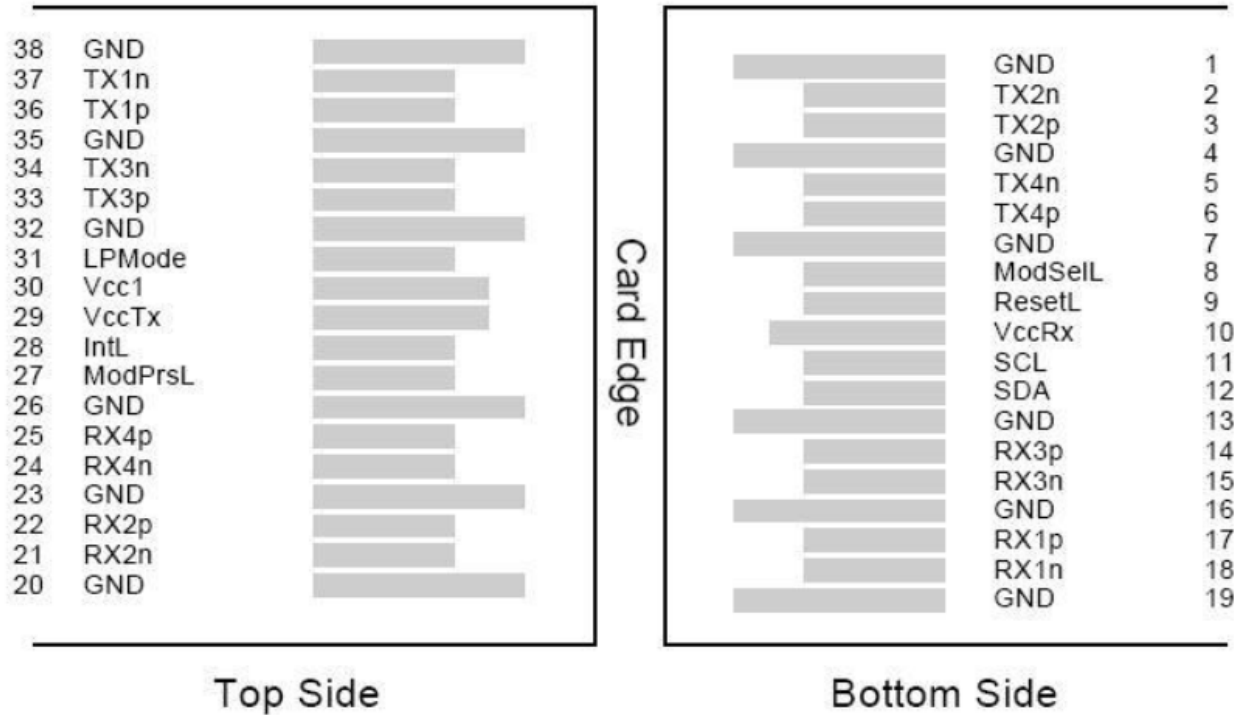

Figure 1. Host PCB QSFP28 pad assignment top view

Absolute Maximum Ratings

Stresses in excess of the absolute maximum ratings can cause permanent damage to the device. These are absolute stress ratings only. Functional operation of the device is not implied at these or any other conditions in excess of those given in the operational sections of the data sheet. Exposure to absolute maximum ratings for extended periods can adversely affect device reliability.

Table 3. Absolute Maximum Ratings

Parameter	Symbol	Minimum	Maximum	Unit
Storage Temperature	T_S	-40	85	°C
Relative Humidity	RH	5	95	%
Supply Voltage	V_{CC}	-0.5	4.0	V

Recommended Operating Conditions

Table 4. Recommended Operating Conditions

Parameter	Symbol	Min	Typ	Max	Unit
Operating Case Temperature	T_C	-5	25	70	°C
Supply Voltage	V_{CC}	3.135	3.3	3.465	V
Data Rate PER Channel	-	-	25.78125		Gb/s

Transceiver Electrical Characteristics

Table 5. Transceiver Electrical Characteristics

Parameter	Symbol	Minimum	Typical	Maximum	Unit	Notes
Module Supply Current	I_{CC}	-	-	1100	mA	-
Power Dissipation	P_D	-	-	3500	mW	-
Transmitter						
-Single-ended Input Voltage Tolerance	-	-0.3	-	4.0	V	-
Input Differential Impedance	Z_{IN}	-	100	-	Ω	-
Differential Data Input Swing	$V_{IN,P-P}$	190	-	700	mV _{P-P}	-
AC Common Mode Input Voltage Tolerance	-	15	-	-	mV	-
Differential Input Voltage Swing Threshold	-	50	-	-	mV _{pp}	-
Receiver						
Single-ended Output Voltage	-	-0.3	-	4.0	V	-
Output Differential Impedance	Z_O	90	100	110	Ω	-
Differential Data Output Swing	$V_{OUT,P-P}$	300	-	850	mV _{P-P}	-
AC Common Mode Output Voltage	-	-	-	7.5	mV	-

Transmitter Optical Characteristics

Table 6. Transmitter Optical Characteristics

Parameter	Symbol	Minimum	Typical	Maximum	Unit	Notes
Launch Optical Power per lane	P _o	-4.3	-	+4.5	dBm	1
Total Launch Optical Power	P _o	-	-	+10.5	dBm	1
Center Wavelength Range	L1	1294.53	1295.56	1296.59	nm	-
	L2	1299.02	1300.05	1301.09	nm	-
	L3	1303.54	1304.58	1305.63	nm	-
	L4	1308.09	1309.14	1310.19	nm	-
Extinction Ratio	EX	4.0	-	-	dB	2
Spectral width(-20dB)	Δλ	-	-	1	nm	-
Side Mode Suppression Ratio	SMSR	30	-	-	dB	-
Optical Return Loss Tolerance	ORLT	-	-	20	dB	-
Pout @TX-Disable Asserted	P _{off}	-	-	-30	dBm	1
Eye Mask {X1, X2, X3, Y1, Y2, Y3}		{0.25, 0.4, 0.45, 0.25, 0.28, 0.4}				

Notes:

1. The optical power is launched into SMF.
2. Measured with a PRBS 2³¹-1 test pattern @25.78125Gbps.

Receiver Optical Characteristics

Table 7. Receiver Optical Characteristics

Parameter	Symbol	Minimum	Typical	Maximum	Unit	Notes
Center Wavelength	L1	1294.53	1295.56	1296.59	nm	-
	L2	1299.02	1300.05	1301.09	nm	-
	L3	1303.54	1304.58	1305.63	nm	-
	L4	1308.09	1309.14	1310.19	nm	-
Sensitivity per Channel	S	-	-	-8.6	dBm	1
Damage Threshold(each channel)	POL	4.5	-	-	dBm	-
Optical Return Loss	ORL	26	-	-	dB	-
LOS De-Assert	LOSD	-	-	-11.6	dBm	-
LOS Assert	LOSA	-24	-	-	dBm	-
LOS Hysteresis	-	0.5	-	-	dB	-

Notes:

1. Measured with PRBS 2³¹-1 test pattern, 25.78125Gb/s;

Recommended Host Board Power Supply Filter Network

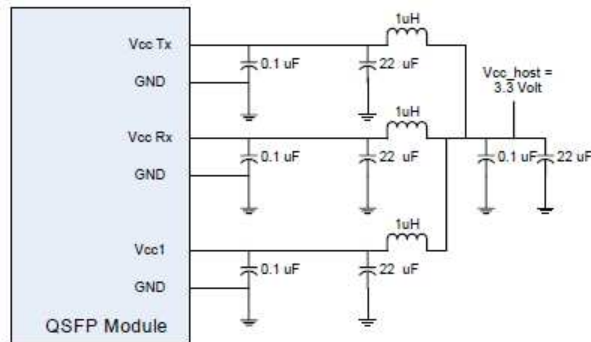

Figure 2. Recommended Host Board Power Supply Filter Network

Recommended Application Interface Block Diagram

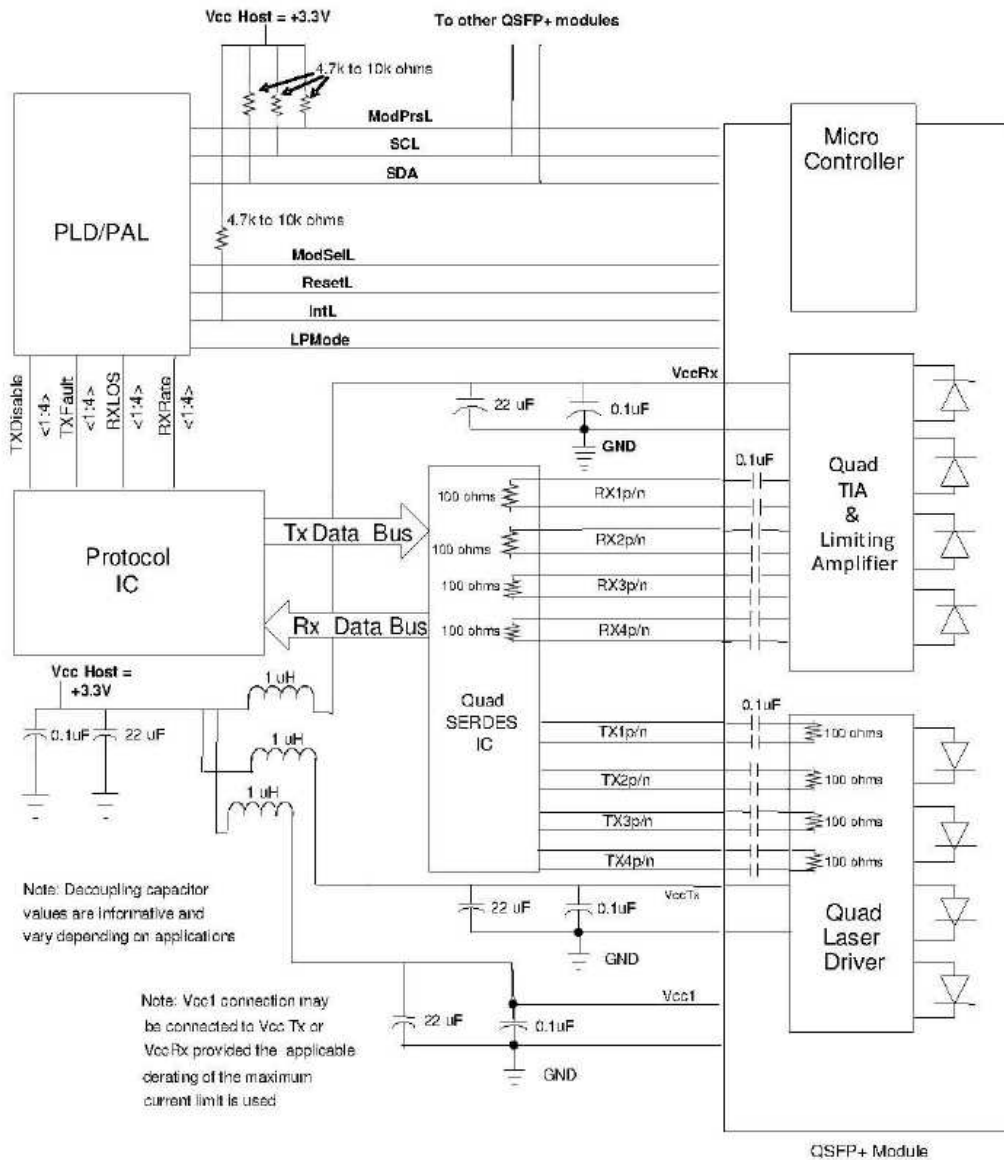

Figure 4. Recommended Application Interface Block Diagram

Mechanical specifications

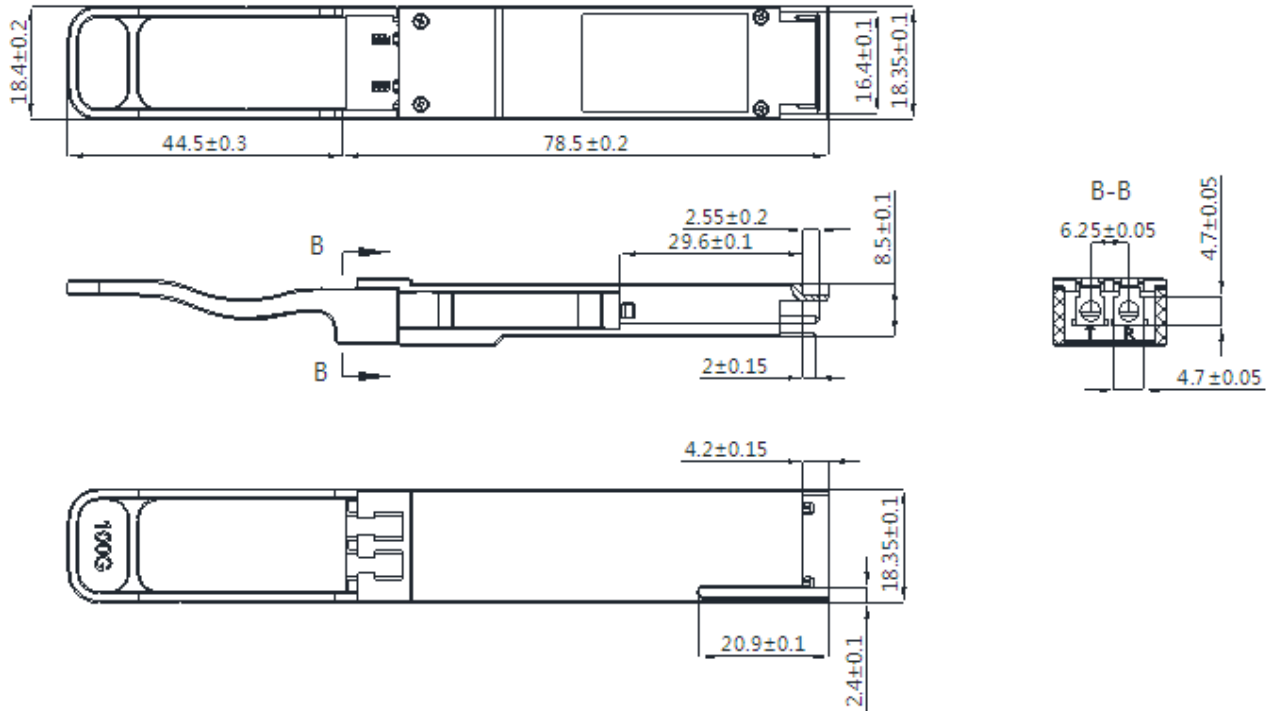

Figure 5. Outline Drawing

For More Information

Linktel Technologies Co., Ltd

sales@linkteltech.com

<http://www.linkteltech.com>

Linktel China

No. 20, University Science Park Road,
East Lake Hi-tech Development Zone, Wuhan, 430223, China
Tel: +86 27-87929302

Linktel USA

1601 McCarthy Blvd #9, Milpitas, CA 95035, USA
+1 408 807 0482
linktelus@linkteltech.com